

1

2

3

4

5

6

A

A

B

B

C

C

D

D

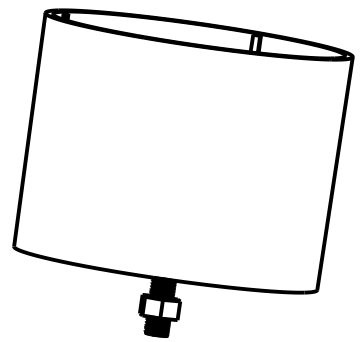
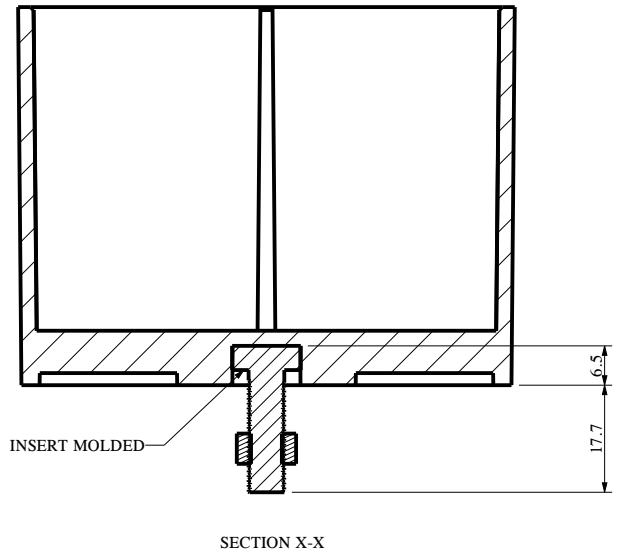
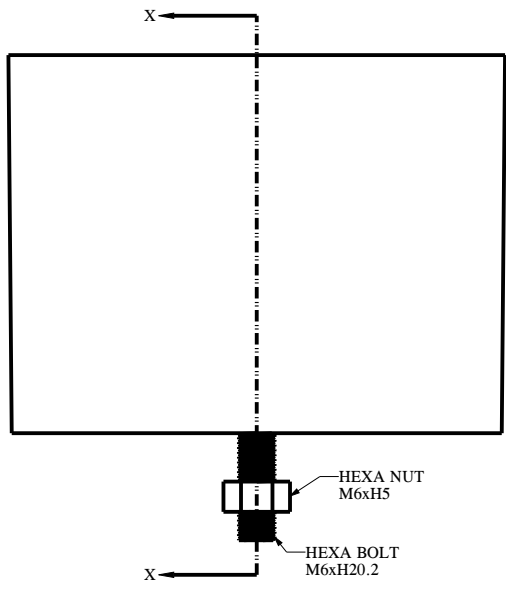

1

2

3

4

5

6

1

2

3

4

5

6

A

A

B

B

C

C

D

D

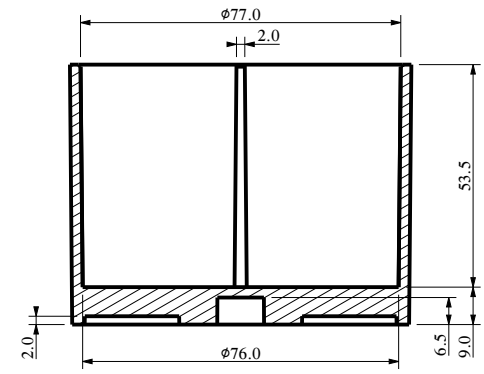
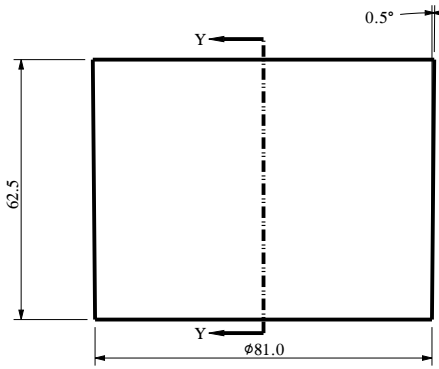

SECTION Y-Y

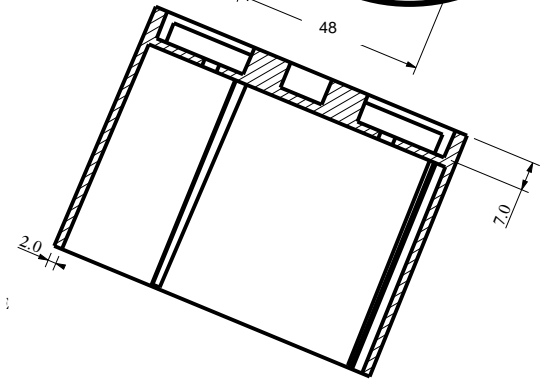
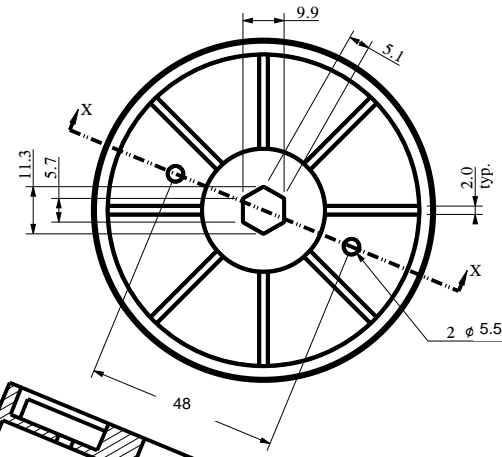

SECTION X-X

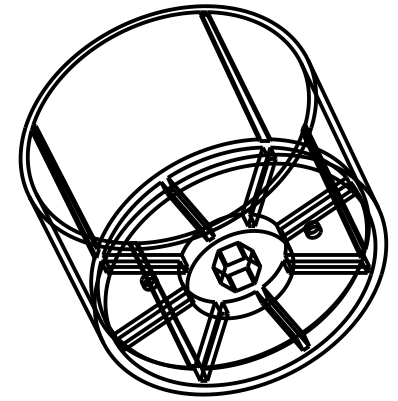

1

2

3

4

5

6

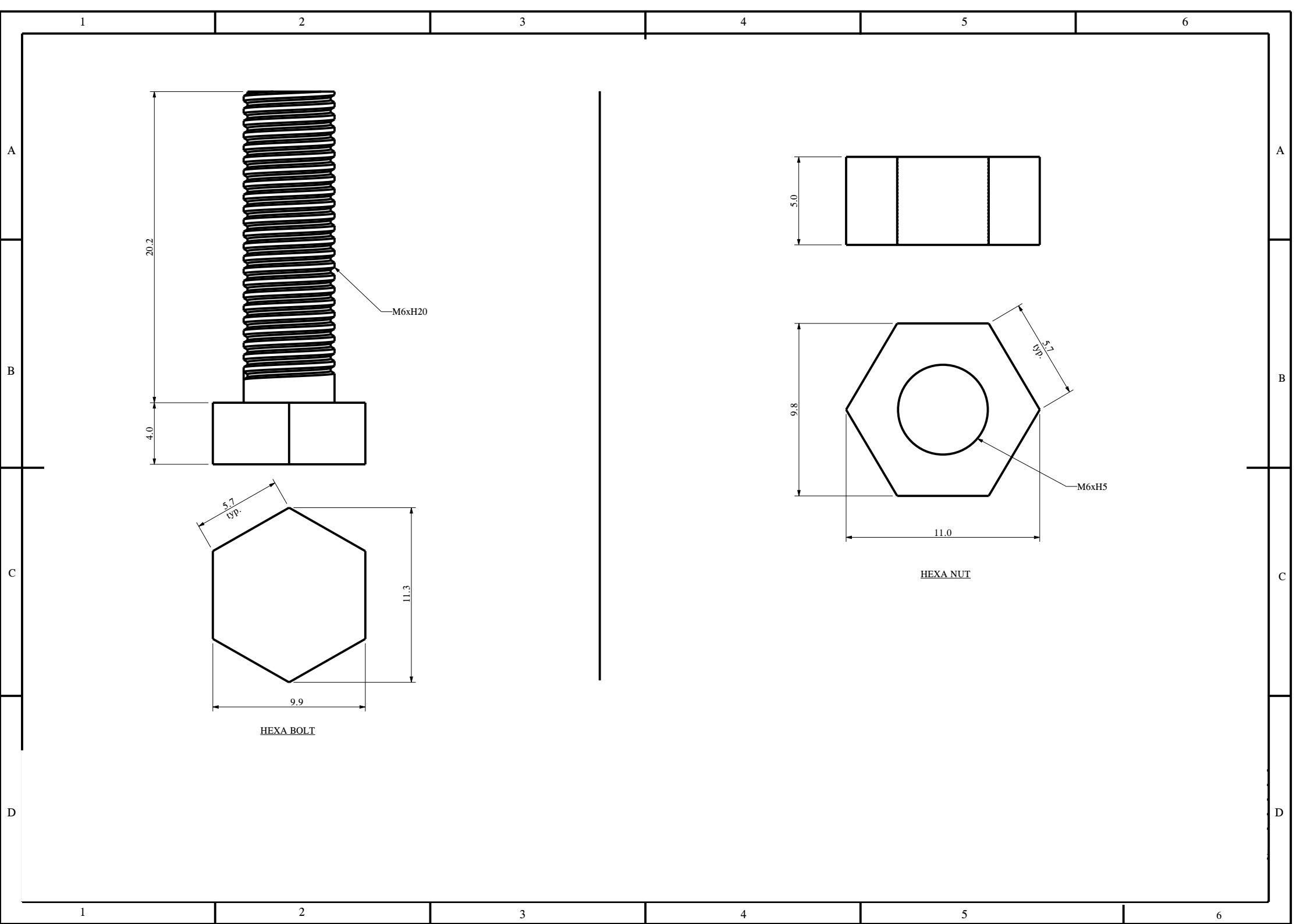

1

2

3

4

5

6

A

A

B

B

C

C

D

D

1

2

3

4

5

6